



# THE CMU BOOK

COLORS | TEXTURES | SHAPES | ASTM



**MUTUALMATERIALS<sup>®</sup>**

[www.mutualmaterials.com](http://www.mutualmaterials.com)

# COLORS

<b>BURGUNDY</b>	<b>DRIFTWOOD</b>	<b>ROSE BROWN</b>
<b>BURNT ORANGE</b>	<b>KHAKI</b>	<b>SABLE *</b>
<b>CASCADE BLEND *</b>	<b>MESA TAN</b>	<b>SANDSTONE *</b>
<b>CASTLE WHITE*</b>	<b>MOUNTAIN</b>	<b>SUMMIT *</b>
<b>CHARCOAL</b>	<b>BROWN</b>	<b>WILLOW *</b>
<b>COCOA</b>	<b>NATURAL</b>	<b>WINTER SKY *</b>
<b>DEEP PLUM</b>	<b>ONYX *</b>	

\* Premium colors

# SHAPES

**4 Inch | 6 Inch | 8 Inch**

**10 Inch | 12 Inch**

**8 Inch Lintels | 16 Inch Lintels**

**L-Corners | Sloped Caps | CMU Sills**



**MUTUALMATERIALS®**

[www.mutualmaterials.com](http://www.mutualmaterials.com)



# THE CMU BOOK

COLORS | TEXTURES | SHAPES | ASTM

COLOR\*: **Burgundy**

TEXTURE: **Ground Face**

TYPE\*\*: **Special Order**

PLANT: **Kent, WA; Empire, OR**

ASTM: **ASTM C-90**



- *Due to the limitations of photography, the actual product shipped is not guaranteed to duplicate the image shown here. Final color and product selection should be made from actual samples.*
- *\*\* Special Order Colors require a minimum order. Additional production time should be allowed.*

### Considering CMU for your project?

For samples and ordering information contact your Mutual Materials Sales Representative or call (888) 688-8250.



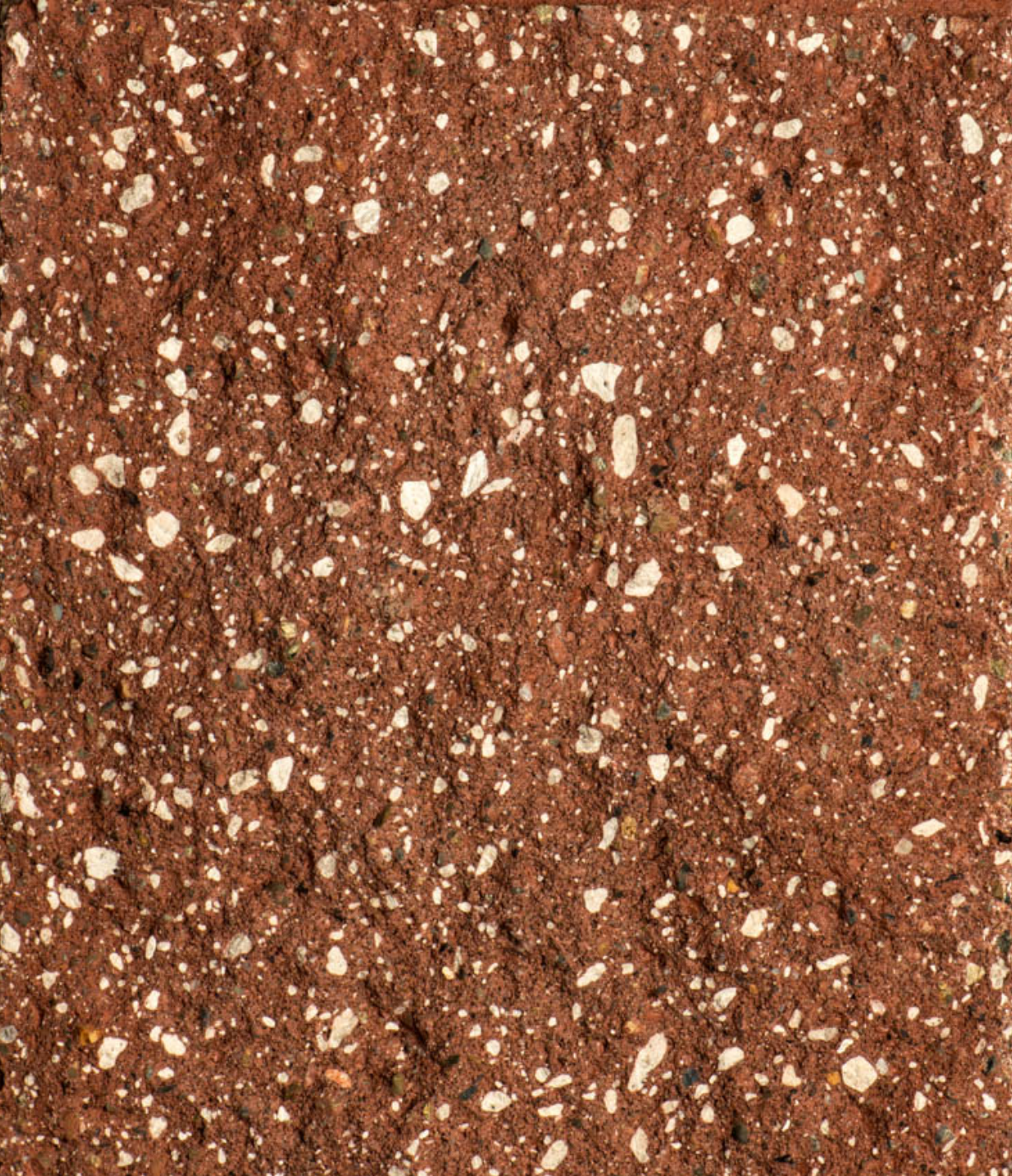

# THE CMU BOOK

COLORS | TEXTURES | SHAPES | ASTM

COLOR\*: **Burgundy**

TEXTURE: **Split Face**

TYPE\*\*: **Special Order**

PLANT: **Kent, WA; Empire, OR**

ASTM: **ASTM C-90**

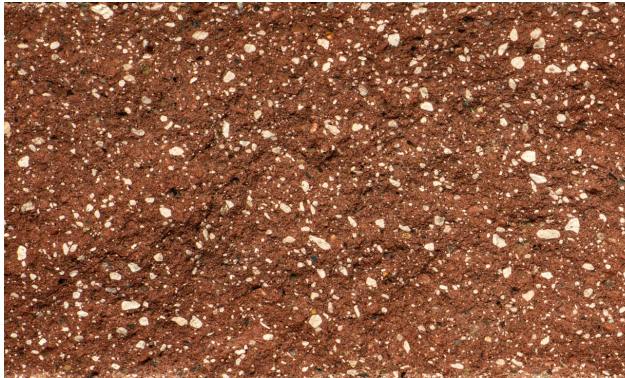

- *Due to the limitations of photography, the actual product shipped is not guaranteed to duplicate the image shown here. Final color and product selection should be made from actual samples.*
- *\*\* Special Order Colors require a minimum order. Additional production time should be allowed.*

### Considering CMU for your project?

For samples and ordering information contact your Mutual Materials Sales Representative or call (888) 688-8250.





# THE CMU BOOK

COLORS | TEXTURES | SHAPES | ASTM

COLOR\*: **Burnt Orange**

TEXTURE: **Ground Face**

TYPE\*\*: **Special Order**

PLANT: **Kent, WA; Empire, OR**

ASTM: **ASTM C-90**



- *Due to the limitations of photography, the actual product shipped is not guaranteed to duplicate the image shown here. Final color and product selection should be made from actual samples.*
- *\*\* Special Order Colors require a minimum order. Additional production time should be allowed.*

### Considering CMU for your project?

For samples and ordering information contact your Mutual Materials Sales Representative or call (888) 688-8250.



**MUTUALMATERIALS®**

[www.mutualmaterials.com](http://www.mutualmaterials.com)



# THE CMU BOOK

COLORS | TEXTURES | SHAPES | ASTM

COLOR\*: **Burnt Orange**

TEXTURE: **Split Face**

TYPE\*\*: **Special Order**

PLANT: **Kent, WA; Empire, OR**

ASTM: **ASTM C-90**



- *Due to the limitations of photography, the actual product shipped is not guaranteed to duplicate the image shown here. Final color and product selection should be made from actual samples.*
- *\*\* Special Order Colors require a minimum order. Additional production time should be allowed.*

### Considering CMU for your project?

For samples and ordering information contact your Mutual Materials Sales Representative or call (888) 688-8250.



# THE CMU BOOK

COLORS | TEXTURES | SHAPES | ASTM

COLOR\*: **Cascade Blend** (PREMIUM COLOR)

TEXTURE: **Ground Face**

TYPE\*\*: **Special Order**

PLANT: **Empire, OR**

ASTM: **ASTM C-90**

- *Due to the limitations of photography, the actual product shipped is not guaranteed to duplicate the image shown here. Final color and product selection should be made from actual samples.*
- *\*\* Special Order Colors require a minimum order. Additional production time should be allowed.*

## Considering CMU for your project?

For samples and ordering information contact your  
Mutual Materials Sales Representative or call  
(888) 688-8250.



**MUTUALMATERIALS®**

[www.mutualmaterials.com](http://www.mutualmaterials.com)



# THE CMU BOOK

COLORS | TEXTURES | SHAPES | ASTM

COLOR\*: **Cascade Blend** (PREMIUM COLOR)

TEXTURE: **Split Face**

TYPE\*\*: **Special Order**

PLANT: **Empire, OR**

ASTM: **ASTM C-90**

- *Due to the limitations of photography, the actual product shipped is not guaranteed to duplicate the image shown here. Final color and product selection should be made from actual samples.*
- *\*\* Special Order Colors require a minimum order. Additional production time should be allowed.*

### Considering CMU for your project?

For samples and ordering information contact your Mutual Materials Sales Representative or call (888) 688-8250.





P

# THE CMU BOOK

COLORS | TEXTURES | SHAPES | ASTM

COLOR\*: **Castle White** (PREMIUM COLOR)

TEXTURE: **Ground Face**

TYPE\*\*: **Special Order**

PLANT: **Kent, WA; Empire, OR**

ASTM: **ASTM C-90**



- *Due to the limitations of photography, the actual product shipped is not guaranteed to duplicate the image shown here. Final color and product selection should be made from actual samples.*
- *\*\* Special Order Colors require a minimum order. Additional production time should be allowed.*

## Considering CMU for your project?

For samples and ordering information contact your Mutual Materials Sales Representative or call (888) 688-8250.



**MUTUALMATERIALS®**

[www.mutualmaterials.com](http://www.mutualmaterials.com)



# THE CMU BOOK

COLORS | TEXTURES | SHAPES | ASTM

COLOR\*: **Castle White** (PREMIUM COLOR)

TEXTURE: **Split Face**

TYPE\*\*: **Special Order**

PLANT: **Kent, WA; Empire, OR**

ASTM: **ASTM C-90**



- *Due to the limitations of photography, the actual product shipped is not guaranteed to duplicate the image shown here. Final color and product selection should be made from actual samples.*
- *\*\* Special Order Colors require a minimum order. Additional production time should be allowed.*

### Considering CMU for your project?

For samples and ordering information contact your Mutual Materials Sales Representative or call (888) 688-8250.



# THE CMU BOOK

COLORS | TEXTURES | SHAPES | ASTM

COLOR\*: **Charcoal**

TEXTURE: **Ground Face**

TYPE\*\*: **Special Order**

PLANT: **Kent, WA; Empire, OR**

ASTM: **ASTM C-90**



- *Due to the limitations of photography, the actual product shipped is not guaranteed to duplicate the image shown here. Final color and product selection should be made from actual samples.*
- *\*\* Special Order Colors require a minimum order. Additional production time should be allowed.*

### Considering CMU for your project?

For samples and ordering information contact your Mutual Materials Sales Representative or call (888) 688-8250.





# THE CMU BOOK

COLORS | TEXTURES | SHAPES | ASTM

COLOR\*: **Charcoal**

TEXTURE: **Split Face**

TYPE\*\*: **Special Order**

PLANT: **Kent, WA; Empire, OR**

ASTM: **ASTM C-90**



- *Due to the limitations of photography, the actual product shipped is not guaranteed to duplicate the image shown here. Final color and product selection should be made from actual samples.*
- *\*\* Special Order Colors require a minimum order. Additional production time should be allowed.*

### Considering CMU for your project?

For samples and ordering information contact your Mutual Materials Sales Representative or call (888) 688-8250.



# THE CMU BOOK

COLORS | TEXTURES | SHAPES | ASTM

COLOR\*: **Cocoa**

TEXTURE: **Ground Face**

TYPE\*\*: **Special Order**

PLANT: **Kent, WA; Empire, OR**

ASTM: **ASTM C-90**



- *Due to the limitations of photography, the actual product shipped is not guaranteed to duplicate the image shown here. Final color and product selection should be made from actual samples.*
- *\*\* Special Order Colors require a minimum order. Additional production time should be allowed.*

## Considering CMU for your project?

For samples and ordering information contact your  
Mutual Materials Sales Representative or call  
(888) 688-8250.



**MUTUALMATERIALS®**

[www.mutualmaterials.com](http://www.mutualmaterials.com)

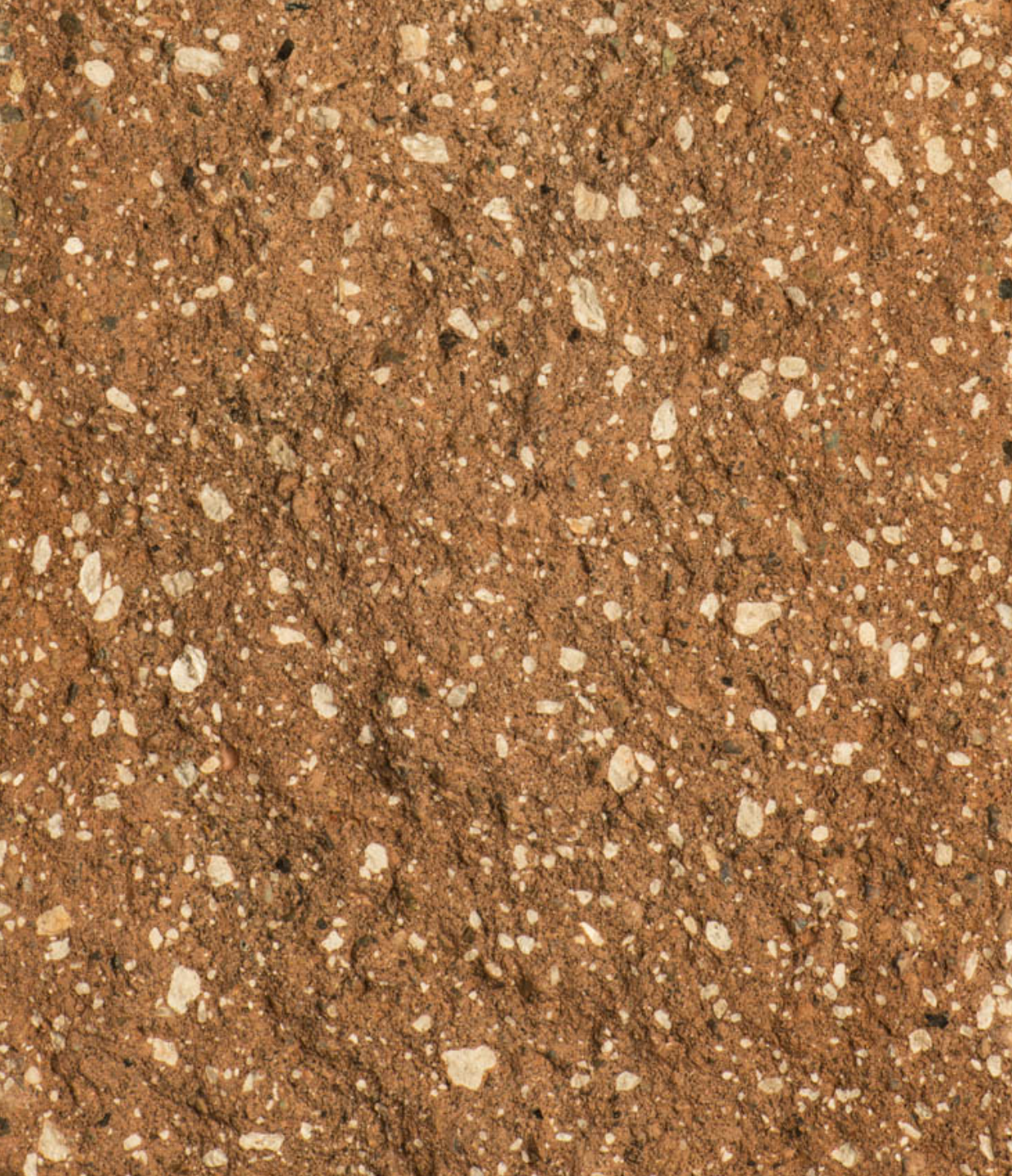

# THE CMU BOOK

COLORS | TEXTURES | SHAPES | ASTM

COLOR\*: **Cocoa**

TEXTURE: **Split Face**

TYPE\*\*: **Special Order**

PLANT: **Kent, WA; Empire, OR**

ASTM: **ASTM C-90**



- *Due to the limitations of photography, the actual product shipped is not guaranteed to duplicate the image shown here. Final color and product selection should be made from actual samples.*
- *\*\* Special Order Colors require a minimum order. Additional production time should be allowed.*

### Considering CMU for your project?

For samples and ordering information contact your Mutual Materials Sales Representative or call (888) 688-8250.





# THE CMU BOOK

COLORS | TEXTURES | SHAPES | ASTM

COLOR\*: **Deep Plum**

TEXTURE: **Ground Face**

TYPE\*\*: **Special Order**

PLANT: **Kent, WA; Empire, OR**

ASTM: **ASTM C-90**



- *Due to the limitations of photography, the actual product shipped is not guaranteed to duplicate the image shown here. Final color and product selection should be made from actual samples.*
- *\*\* Special Order Colors require a minimum order. Additional production time should be allowed.*

### Considering CMU for your project?

For samples and ordering information contact your Mutual Materials Sales Representative or call (888) 688-8250.





# THE CMU BOOK

COLORS | TEXTURES | SHAPES | ASTM

COLOR\*: **Deep Plum**

TEXTURE: **Split Face**

TYPE\*\*: **Special Order**

PLANT: **Kent, WA; Empire, OR**

ASTM: **ASTM C-90**



- *Due to the limitations of photography, the actual product shipped is not guaranteed to duplicate the image shown here. Final color and product selection should be made from actual samples.*
- *\*\* Special Order Colors require a minimum order. Additional production time should be allowed.*

### Considering CMU for your project?

For samples and ordering information contact your Mutual Materials Sales Representative or call (888) 688-8250.







# THE CMU BOOK

COLORS | TEXTURES | SHAPES | ASTM

COLOR\*: **Driftwood**

TEXTURE: **Ground Face**

TYPE\*\*: **Special Order**

PLANT: **Kent, WA; Empire, OR**

ASTM: **ASTM C-90**



- *Due to the limitations of photography, the actual product shipped is not guaranteed to duplicate the image shown here. Final color and product selection should be made from actual samples.*
- *\*\* Special Order Colors require a minimum order. Additional production time should be allowed.*

### Considering CMU for your project?

For samples and ordering information contact your Mutual Materials Sales Representative or call (888) 688-8250.





# THE CMU BOOK

COLORS | TEXTURES | SHAPES | ASTM

COLOR\*: **Driftwood**

TEXTURE: **Split Face**

TYPE\*\*: **Special Order**

PLANT: **Kent, WA; Empire, OR**

ASTM: **ASTM C-90**



- *Due to the limitations of photography, the actual product shipped is not guaranteed to duplicate the image shown here. Final color and product selection should be made from actual samples.*
- *\*\* Special Order Colors require a minimum order. Additional production time should be allowed.*

## Considering CMU for your project?

For samples and ordering information contact your Mutual Materials Sales Representative or call (888) 688-8250.



**MUTUALMATERIALS®**

[www.mutualmaterials.com](http://www.mutualmaterials.com)

# THE CMU BOOK

COLORS | TEXTURES | SHAPES | ASTM

COLOR\*: **Khaki**

TEXTURE: **Ground Face**

TYPE\*\*: **Special Order**

PLANT: **Kent, WA; Empire, OR**

ASTM: **ASTM C-90**



- *Due to the limitations of photography, the actual product shipped is not guaranteed to duplicate the image shown here. Final color and product selection should be made from actual samples.*
- *\*\* Special Order Colors require a minimum order. Additional production time should be allowed.*

## Considering CMU for your project?

For samples and ordering information contact your Mutual Materials Sales Representative or call (888) 688-8250.



**MUTUALMATERIALS®**

[www.mutualmaterials.com](http://www.mutualmaterials.com)

# THE CMU BOOK

COLORS | TEXTURES | SHAPES | ASTM

COLOR\*: **Khaki**

TEXTURE: **Split Face**

TYPE\*\*: **Special Order**

PLANT: **Kent, WA; Empire, OR**

ASTM: **ASTM C-90**



- *Due to the limitations of photography, the actual product shipped is not guaranteed to duplicate the image shown here. Final color and product selection should be made from actual samples.*
- *\*\* Special Order Colors require a minimum order. Additional production time should be allowed.*

## Considering CMU for your project?

For samples and ordering information contact your Mutual Materials Sales Representative or call (888) 688-8250.



**MUTUALMATERIALS®**

[www.mutualmaterials.com](http://www.mutualmaterials.com)



# THE CMU BOOK

COLORS | TEXTURES | SHAPES | ASTM

COLOR\*: **Mesa Tan**

TEXTURE: **Ground Face**

TYPE\*\*: **Special Order**

PLANT: **Kent, WA; Empire, OR**

ASTM: **ASTM C-90**



- *Due to the limitations of photography, the actual product shipped is not guaranteed to duplicate the image shown here. Final color and product selection should be made from actual samples.*
- *\*\* Special Order Colors require a minimum order. Additional production time should be allowed.*

### Considering CMU for your project?

For samples and ordering information contact your Mutual Materials Sales Representative or call (888) 688-8250.



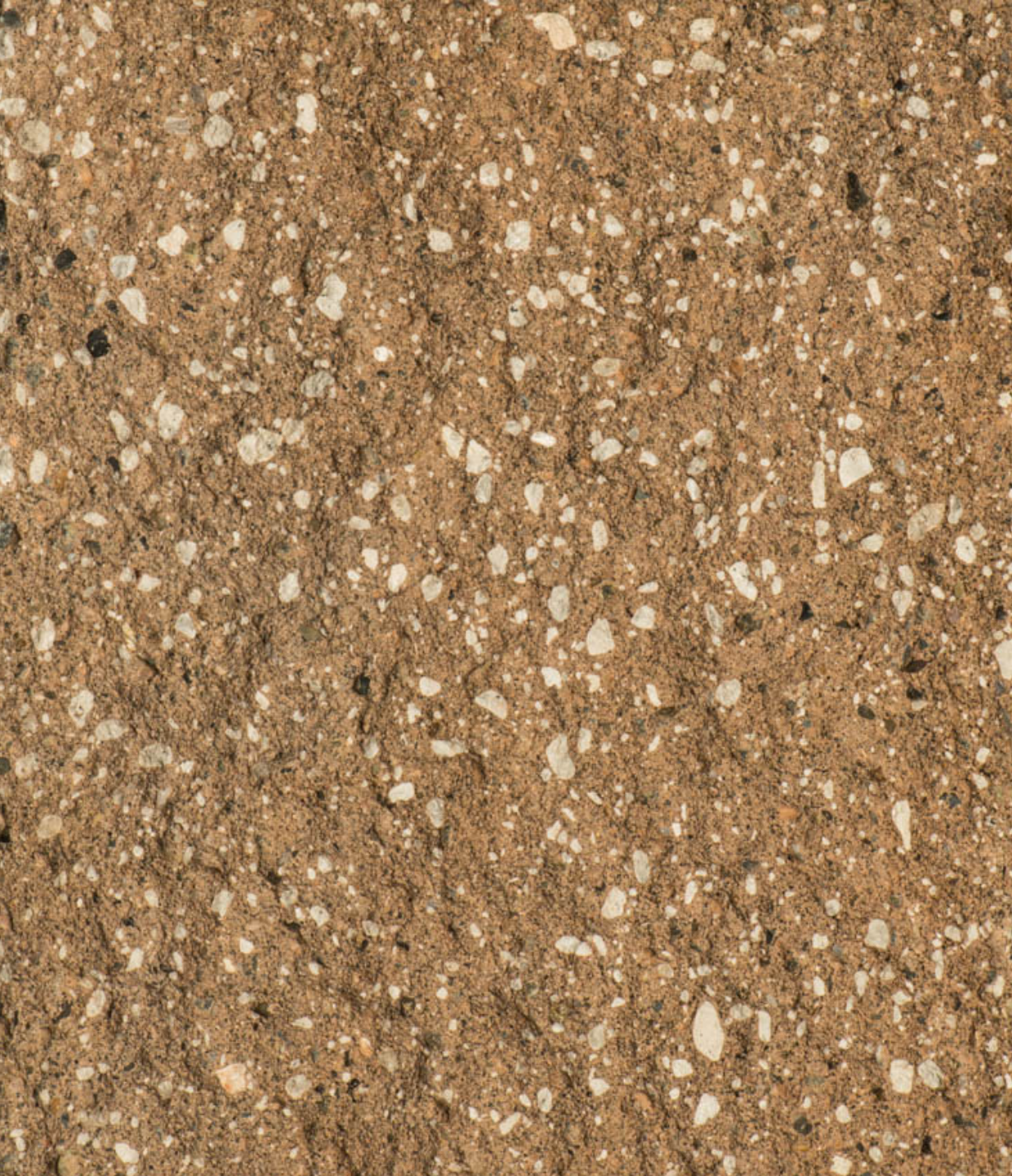

# THE CMU BOOK

COLORS | TEXTURES | SHAPES | ASTM

COLOR\*: Mesa Tan

TEXTURE: Split Face

TYPE\*\*: Special Order

PLANT: Kent, WA; Empire, OR

ASTM: ASTM C-90

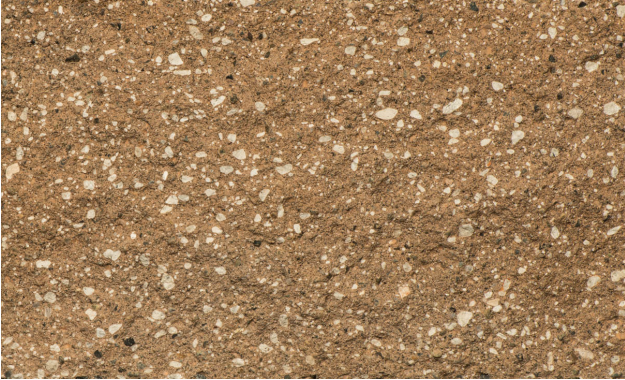

- *Due to the limitations of photography, the actual product shipped is not guaranteed to duplicate the image shown here. Final color and product selection should be made from actual samples.*
- *\*\* Special Order Colors require a minimum order. Additional production time should be allowed.*

### Considering CMU for your project?

For samples and ordering information contact your Mutual Materials Sales Representative or call (888) 688-8250.





# THE CMU BOOK

COLORS | TEXTURES | SHAPES | ASTM

COLOR\*: **Mountain Brown**

TEXTURE: **Ground Face**

TYPE\*\*: **Special Order**

PLANT: **Kent, WA; Empire, OR**

ASTM: **ASTM C-90**



- *Due to the limitations of photography, the actual product shipped is not guaranteed to duplicate the image shown here. Final color and product selection should be made from actual samples.*
- *\*\* Special Order Colors require a minimum order. Additional production time should be allowed.*

## Considering CMU for your project?

For samples and ordering information contact your Mutual Materials Sales Representative or call (888) 688-8250.



**MUTUALMATERIALS®**

[www.mutualmaterials.com](http://www.mutualmaterials.com)



# THE CMU BOOK

COLORS | TEXTURES | SHAPES | ASTM

COLOR\*: **Mountain Brown**

TEXTURE: **Split Face**

TYPE\*\*: **Special Order**

PLANT: **Kent, WA; Empire, OR**

ASTM: **ASTM C-90**



- *Due to the limitations of photography, the actual product shipped is not guaranteed to duplicate the image shown here. Final color and product selection should be made from actual samples.*
- *\*\* Special Order Colors require a minimum order. Additional production time should be allowed.*

### Considering CMU for your project?

For samples and ordering information contact your Mutual Materials Sales Representative or call (888) 688-8250.





# THE CMU BOOK

COLORS | TEXTURES | SHAPES | ASTM

COLOR\*: **Natural**

TEXTURE: **Ground Face**

TYPE\*\*: **Special Order**

PLANT: **Kent, WA; Empire, OR**

ASTM: **ASTM C-90**



- *Due to the limitations of photography, the actual product shipped is not guaranteed to duplicate the image shown here. Final color and product selection should be made from actual samples.*
- *\*\* Special Order Colors require a minimum order. Additional production time should be allowed.*

### Considering CMU for your project?

For samples and ordering information contact your Mutual Materials Sales Representative or call (888) 688-8250.





# THE CMU BOOK

COLORS | TEXTURES | SHAPES | ASTM

COLOR\*: **Natural**

TEXTURE: **Split Face**

TYPE\*\*: **Special Order**

PLANT: **Kent, WA; Empire, OR**

ASTM: **ASTM C-90**



- *Due to the limitations of photography, the actual product shipped is not guaranteed to duplicate the image shown here. Final color and product selection should be made from actual samples.*
- *\*\* Special Order Colors require a minimum order. Additional production time should be allowed.*

### Considering CMU for your project?

For samples and ordering information contact your Mutual Materials Sales Representative or call (888) 688-8250.





# THE CMU BOOK

COLORS | TEXTURES | SHAPES | ASTM

COLOR\*: **Sable** (PREMIUM COLOR)

TEXTURE: **Ground Face**

TYPE\*\*: **Special Order**

PLANT: **Kent, WA; Empire, OR**

ASTM: **ASTM C-90**



- *Due to the limitations of photography, the actual product shipped is not guaranteed to duplicate the image shown here. Final color and product selection should be made from actual samples.*
- *\*\* Special Order Colors require a minimum order. Additional production time should be allowed.*

### Considering CMU for your project?

For samples and ordering information contact your Mutual Materials Sales Representative or call (888) 688-8250.





# THE CMU BOOK

COLORS | TEXTURES | SHAPES | ASTM

COLOR\*: **Sable** (PREMIUM COLOR)

TEXTURE: **Split Face**

TYPE\*\*: **Special Order**

PLANT: **Kent, WA; Empire, OR**

ASTM: **ASTM C-90**



- *Due to the limitations of photography, the actual product shipped is not guaranteed to duplicate the image shown here. Final color and product selection should be made from actual samples.*
- *\*\* Special Order Colors require a minimum order. Additional production time should be allowed.*

### Considering CMU for your project?

For samples and ordering information contact your Mutual Materials Sales Representative or call (888) 688-8250.



# THE CMU BOOK

COLORS | TEXTURES | SHAPES | ASTM

COLOR\*: **Onyx** (PREMIUM COLOR)

TEXTURE: **Ground Face**

TYPE\*\*: **Special Order**

PLANT: **Kent, WA; Empire, OR**

ASTM: **ASTM C-90**



- *Due to the limitations of photography, the actual product shipped is not guaranteed to duplicate the image shown here. Final color and product selection should be made from actual samples.*
- *\*\* Special Order Colors require a minimum order. Additional production time should be allowed.*

## Considering CMU for your project?

For samples and ordering information contact your  
Mutual Materials Sales Representative or call  
(888) 688-8250.



**MUTUALMATERIALS®**

[www.mutualmaterials.com](http://www.mutualmaterials.com)

# THE CMU BOOK

COLORS | TEXTURES | SHAPES | ASTM

COLOR\*: **Onyx** (PREMIUM COLOR)

TEXTURE: **Split Face**

TYPE\*\*: **Special Order**

PLANT: **Kent, WA; Empire, OR**

ASTM: **ASTM C-90**

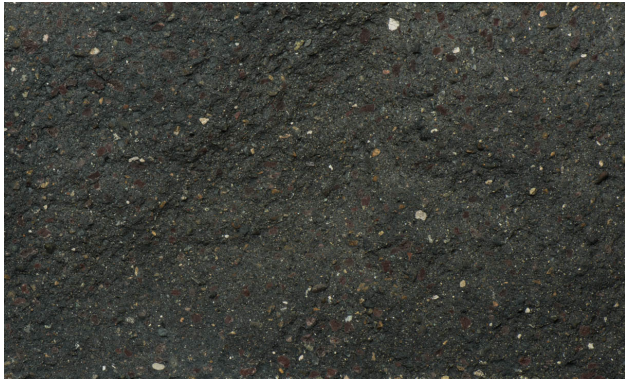

- *Due to the limitations of photography, the actual product shipped is not guaranteed to duplicate the image shown here. Final color and product selection should be made from actual samples.*
- *\*\* Special Order Colors require a minimum order. Additional production time should be allowed.*

### Considering CMU for your project?

For samples and ordering information contact your Mutual Materials Sales Representative or call (888) 688-8250.





# THE CMU BOOK

COLORS | TEXTURES | SHAPES | ASTM

COLOR\*: **Rose Brown**

TEXTURE: **Ground Face**

TYPE\*\*: **Special Order**

PLANT: **Kent, WA; Empire, OR**

ASTM: **ASTM C-90**



- *Due to the limitations of photography, the actual product shipped is not guaranteed to duplicate the image shown here. Final color and product selection should be made from actual samples.*
- *\*\* Special Order Colors require a minimum order. Additional production time should be allowed.*

### Considering CMU for your project?

For samples and ordering information contact your Mutual Materials Sales Representative or call (888) 688-8250.





# THE CMU BOOK

COLORS | TEXTURES | SHAPES | ASTM

COLOR\*: **Rose Brown**

TEXTURE: **Split Face**

TYPE\*\*: **Special Order**

PLANT: **Kent, WA; Empire, OR**

ASTM: **ASTM C-90**



- *Due to the limitations of photography, the actual product shipped is not guaranteed to duplicate the image shown here. Final color and product selection should be made from actual samples.*
- *\*\* Special Order Colors require a minimum order. Additional production time should be allowed.*

### Considering CMU for your project?

For samples and ordering information contact your Mutual Materials Sales Representative or call (888) 688-8250.







# THE CMU BOOK

COLORS | TEXTURES | SHAPES | ASTM

COLOR\*: **Sandstone** (PREMIUM COLOR)

TEXTURE: **Ground Face**

TYPE\*\*: **Special Order**

PLANT: **Kent, WA; Empire, OR**

ASTM: **ASTM C-90**



- *Due to the limitations of photography, the actual product shipped is not guaranteed to duplicate the image shown here. Final color and product selection should be made from actual samples.*
- *\*\* Special Order Colors require a minimum order. Additional production time should be allowed.*

### Considering CMU for your project?

For samples and ordering information contact your Mutual Materials Sales Representative or call (888) 688-8250.



# THE CMU BOOK

COLORS | TEXTURES | SHAPES | ASTM

COLOR\*: **Sandstone** (PREMIUM COLOR)

TEXTURE: **Split Face**

TYPE\*\*: **Special Order**

PLANT: **Kent, WA; Empire, OR**

ASTM: **ASTM C-90**



- *Due to the limitations of photography, the actual product shipped is not guaranteed to duplicate the image shown here. Final color and product selection should be made from actual samples.*
- *\*\* Special Order Colors require a minimum order. Additional production time should be allowed.*

## Considering CMU for your project?

For samples and ordering information contact your Mutual Materials Sales Representative or call (888) 688-8250.



**MUTUALMATERIALS®**

[www.mutualmaterials.com](http://www.mutualmaterials.com)



# THE CMU BOOK

COLORS | TEXTURES | SHAPES | ASTM

COLOR\*: **Summit** (PREMIUM COLOR)

TEXTURE: **Ground Face**

TYPE\*\*: **Special Order**

PLANT: **Empire, OR**

ASTM: **ASTM C-90**



- *Due to the limitations of photography, the actual product shipped is not guaranteed to duplicate the image shown here. Final color and product selection should be made from actual samples.*
- *\*\* Special Order Colors require a minimum order. Additional production time should be allowed.*

## Considering CMU for your project?

For samples and ordering information contact your Mutual Materials Sales Representative or call (888) 688-8250.



**MUTUALMATERIALS®**

[www.mutualmaterials.com](http://www.mutualmaterials.com)



# THE CMU BOOK

COLORS | TEXTURES | SHAPES | ASTM

COLOR\*: **Summit** (PREMIUM COLOR)

TEXTURE: **Split Face**

TYPE\*\*: **Special Order**

PLANT: **Empire, OR**

ASTM: **ASTM C-90**



- *Due to the limitations of photography, the actual product shipped is not guaranteed to duplicate the image shown here. Final color and product selection should be made from actual samples.*
- *\*\* Special Order Colors require a minimum order. Additional production time should be allowed.*

### Considering CMU for your project?

For samples and ordering information contact your Mutual Materials Sales Representative or call (888) 688-8250.



# THE CMU BOOK

COLORS | TEXTURES | SHAPES | ASTM

COLOR\*: **Willow** (PREMIUM COLOR)

TEXTURE: **Ground Face**

TYPE\*\*: **Special Order**

PLANT: **Kent, WA**

ASTM: **ASTM C-90**



- *Due to the limitations of photography, the actual product shipped is not guaranteed to duplicate the image shown here. Final color and product selection should be made from actual samples.*
- *\*\* Special Order Colors require a minimum order. Additional production time should be allowed.*

## Considering CMU for your project?

For samples and ordering information contact your Mutual Materials Sales Representative or call (888) 688-8250.



**MUTUALMATERIALS®**

[www.mutualmaterials.com](http://www.mutualmaterials.com)



# THE CMU BOOK

COLORS | TEXTURES | SHAPES | ASTM

COLOR\*: **Willow** (PREMIUM COLOR)

TEXTURE: **Split Face**

TYPE\*\*: **Special Order**

PLANT: **Kent, WA**

ASTM: **ASTM C-90**



- *Due to the limitations of photography, the actual product shipped is not guaranteed to duplicate the image shown here. Final color and product selection should be made from actual samples.*
- *\*\* Special Order Colors require a minimum order. Additional production time should be allowed.*

### Considering CMU for your project?

For samples and ordering information contact your Mutual Materials Sales Representative or call (888) 688-8250.





# THE CMU BOOK

COLORS | TEXTURES | SHAPES | ASTM

COLOR\*: **Winter Sky** (PREMIUM COLOR)

TEXTURE: **Ground Face**

TYPE\*\*: **Special Order**

PLANT: **Empire, OR**

ASTM: **ASTM C-90**

- *Due to the limitations of photography, the actual product shipped is not guaranteed to duplicate the image shown here. Final color and product selection should be made from actual samples.*
- *\*\* Special Order Colors require a minimum order. Additional production time should be allowed.*

### Considering CMU for your project?

For samples and ordering information contact your Mutual Materials Sales Representative or call (888) 688-8250.



# THE CMU BOOK

COLORS | TEXTURES | SHAPES | ASTM

COLOR\*: **Winter Sky** (PREMIUM COLOR)

TEXTURE: **Split Face**

TYPE\*\*: **Special Order**

PLANT: **Empire, OR**

ASTM: **ASTM C-90**

- *Due to the limitations of photography, the actual product shipped is not guaranteed to duplicate the image shown here. Final color and product selection should be made from actual samples.*
- *\*\* Special Order Colors require a minimum order. Additional production time should be allowed.*

## Considering CMU for your project?

For samples and ordering information contact your  
Mutual Materials Sales Representative or call  
(888) 688-8250.



**MUTUALMATERIALS®**

[www.mutualmaterials.com](http://www.mutualmaterials.com)



# Ground Face

## 4-Inch Units

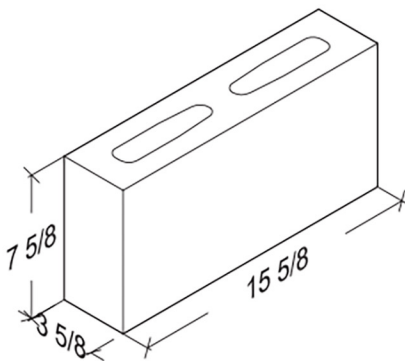

**4-8-16**  
3 5/8" x 7 5/8" x 15 5/8"

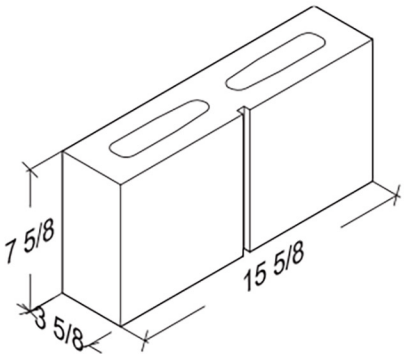

**4-8-16 1-Score**  
3 5/8" x 7 5/8" x 15 5/8"

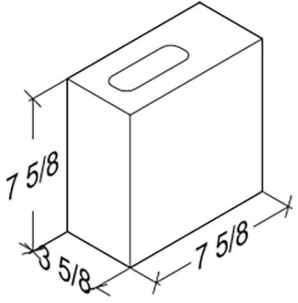

**4-8-8 Half**  
3 5/8" x 7 5/8" x 7 5/8"

# Split Face

## 4-Inch Units

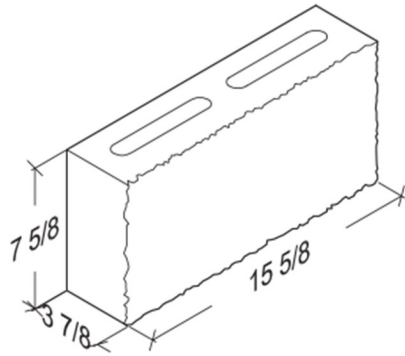

**4-8-16**

3 5/8" x 7 5/8" x 15 5/8"

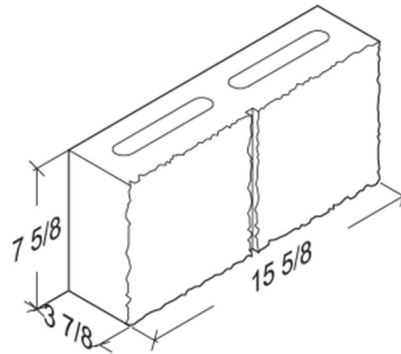

**4-8-16 1-Score**

3 5/8" x 7 5/8" x 15 5/8"

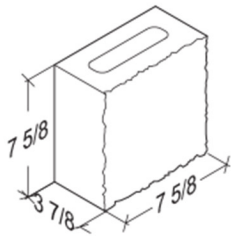

**4-8-8 Half**

3 5/8" x 7 5/8" x 7 5/8"

# Ground Face 6-Inch Units

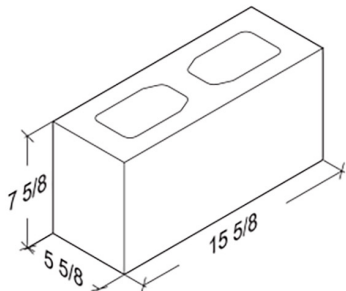

**6-8-16 Standard**  
5 5/8" x 7 5/8" x 15 5/8"

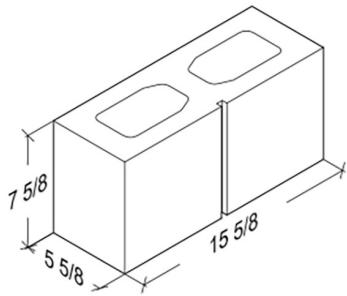

**6-8-16 1-Score**  
5 5/8" x 7 5/8" x 15 5/8"

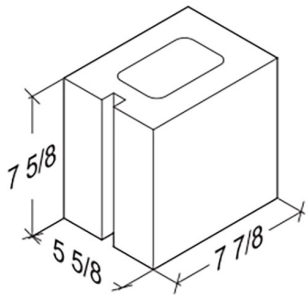

**6-8-8 Half**  
5 5/8" x 7 5/8" x 7 7/8"

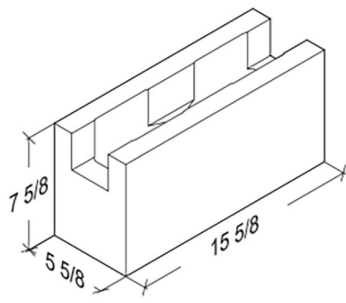

**6-8-16 Bond Beam**  
5 5/8" x 7 5/8" x 15 5/8"

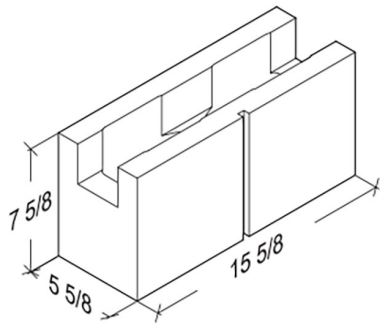

**6-8-16 1-Score Bond Beam**  
5 5/8" x 7 5/8" x 15 5/8"

# Split Face

## 6-Inch Units

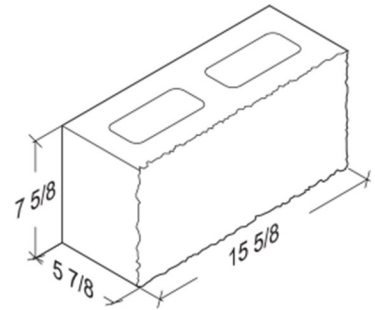

**6-8-16**  
5 5/8" x 7 5/8" x 15 5/8"

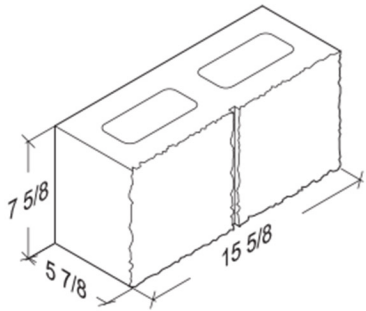

**6-8-16 1-Score**  
5 5/8" x 7 5/8" x 15 5/8"

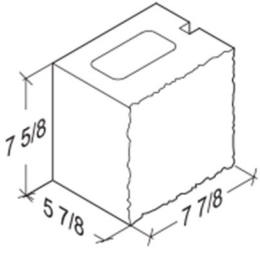

**6-8-8 Half**  
5 5/8" x 7 5/8" x 7 7/8"

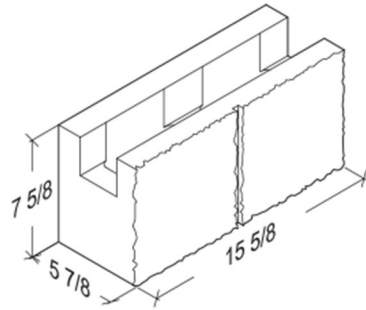

**6-8-16 1-Score Bond Beam**  
5 5/8" x 7 5/8" x 15 5/8"

# Ground Face 8-Inch Units

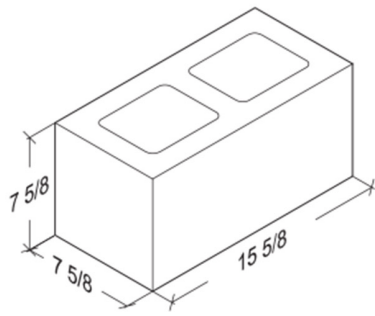

**8-8-16 Standard**  
7 5/8" x 7 5/8" x 15 5/8"

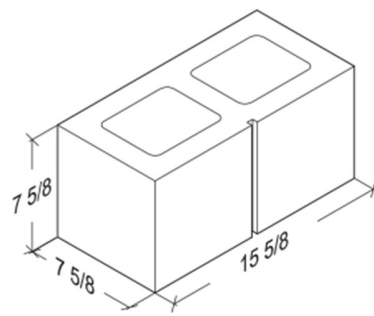

**8-8-16 1-Score**  
7 5/8" x 7 5/8" x 15 5/8"

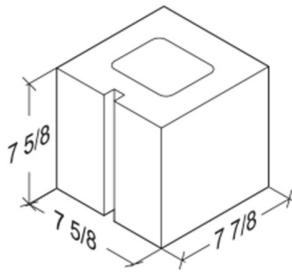

**8-8-8 Half**  
7 5/8" x 7 5/8" x 7 7/8"

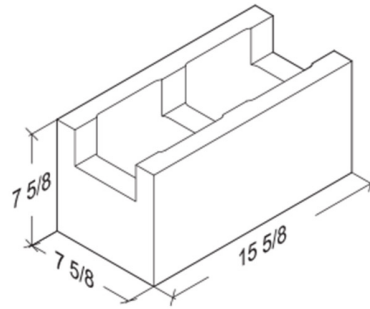

**8-8-16 Bond Beam**  
7 5/8" x 7 5/8" x 15 5/8"

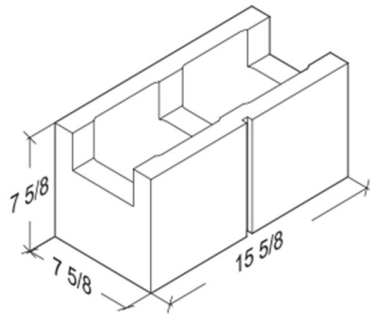

**8-8-16 1-Score Bond Beam**  
7 5/8" x 7 5/8" x 15 5/8"

# Split Face 8-Inch Units

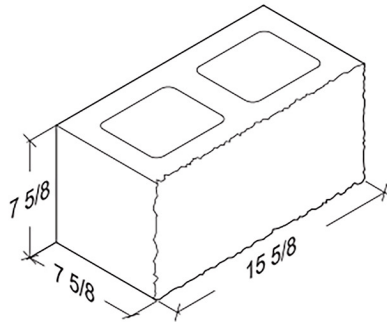

**8-8-16**

7 5/8" x 7 5/8" x 15 5/8"

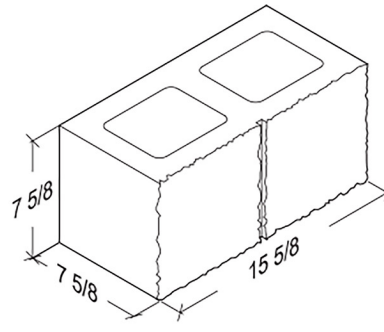

**8-8-16 1-Score**

7 5/8" x 7 5/8" x 15 5/8"

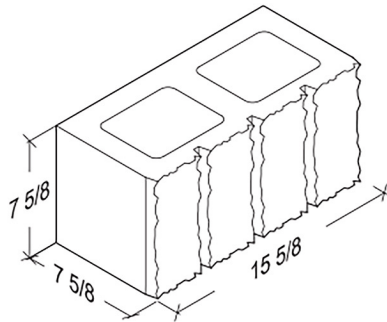

**8-8-16 3-Score**

7 5/8" x 7 5/8" x 15 5/8"

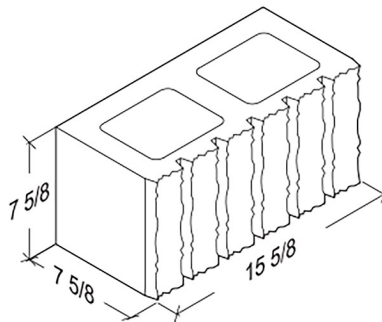

**8-8-16 5-Score**

7 5/8" x 7 5/8" x 15 5/8"

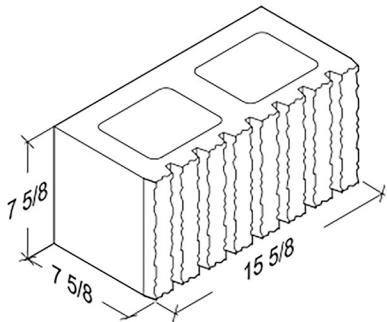

**8-8-16 7-Score**

7 5/8" x 7 5/8" x 15 5/8"

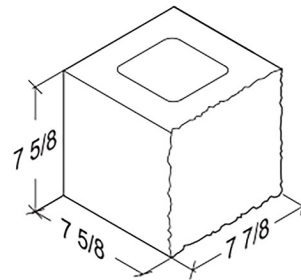

**8-8-8 Half**

7 5/8" x 7 5/8" x 7 7/8"

# Split Face 8-Inch Units

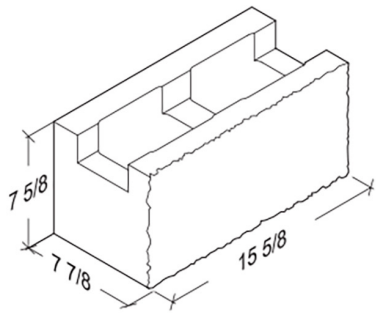

**8-8-16 Bond Beam**  
7 5/8" x 7 7/8" x 15 5/8"

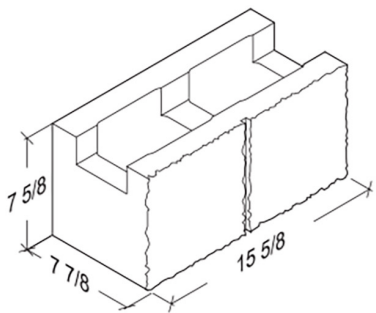

**8-8-16 1-Score Bond Beam**  
7 5/8" x 7 7/8" x 15 5/8"

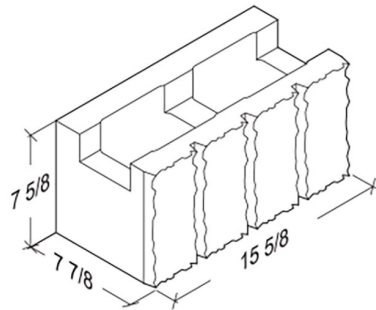

**8-8-16 3-Score Bond Beam**  
7 5/8" x 7 7/8" x 15 5/8"

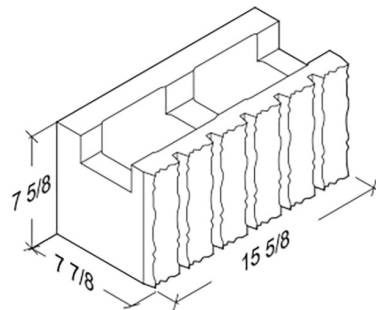

**8-8-16 5-Score Bond Beam**  
7 5/8" x 7 7/8" x 15 5/8"

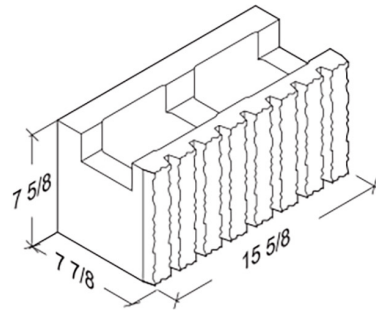

**8-8-16 7-Score Bond Beam**  
7 5/8" x 7 7/8" x 15 5/8"

# Ground Face 10-Inch Units

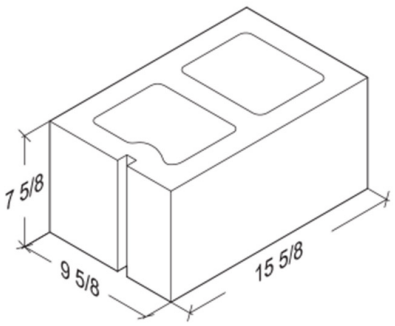

**10-8-16 Standard**  
9 5/8" x 7 5/8" x 15 5/8"

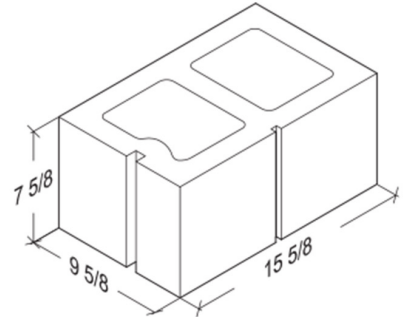

**10-8-16 1-Score**  
9 5/8" x 7 5/8" x 15 5/8"

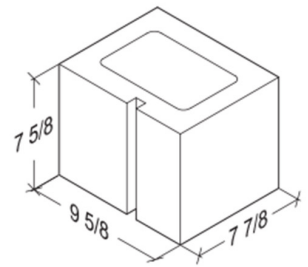

**10-8-8 Half**  
9 5/8" x 7 5/8" x 15 5/8"

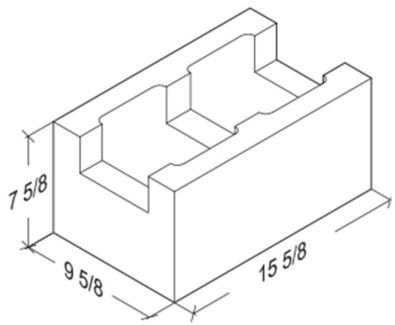

**10-8-16 Bond Beam**  
9 5/8" x 7 5/8" x 15 5/8"

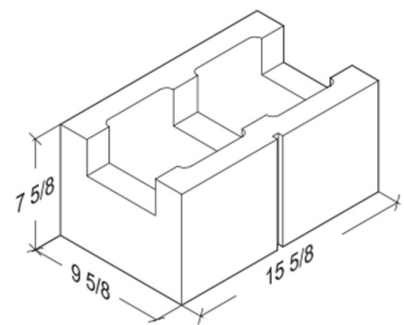

**10-8-16 1-Score Bond Beam**  
9 5/8" x 7 5/8" x 15 5/8"



# Split Face

## 10-Inch Units

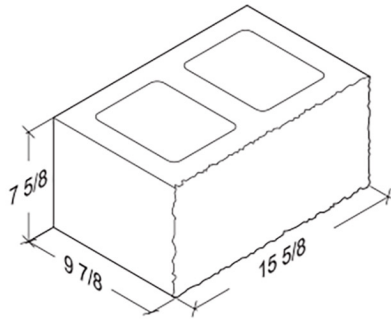

**10-8-16 Standard**

9 7/8" x 7 5/8" x 15 5/8"

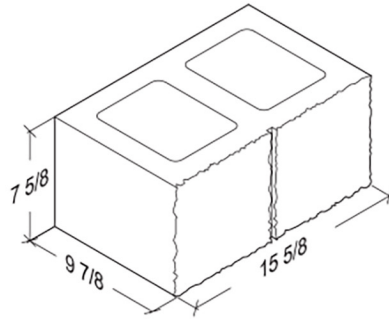

**10-8-16 1-Score**

9 7/8" x 7 5/8" x 15 5/8"

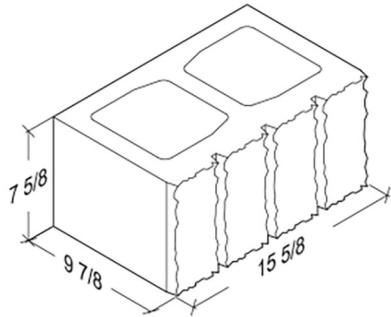

**10-8-163-Score**

9 7/8" x 7 5/8" x 15 5/8"

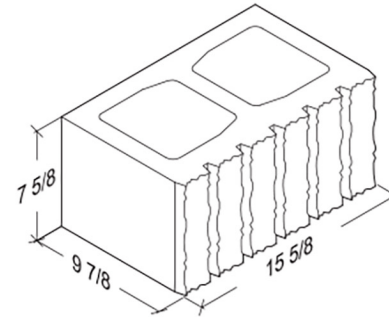

**10-8-165-Score**

9 7/8" x 7 5/8" x 15 5/8"

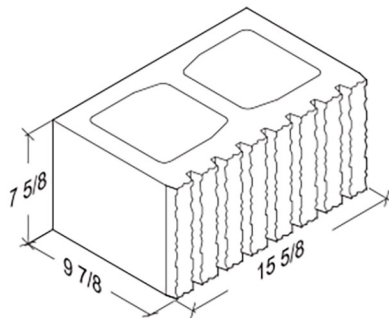

**10-8-167-Score**

9 5/8" x 7 5/8" x 15 5/8"

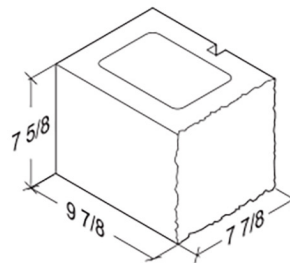

**10-8-8 Half**

9 5/8" x 7 5/8" x 7 7/8"

# Split Face 10-Inch Units

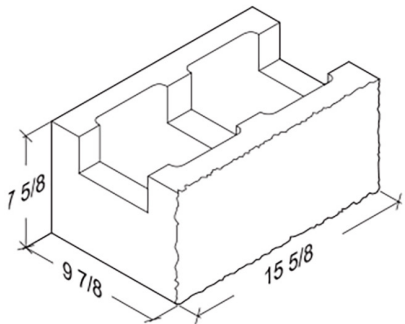

**10-8-16 Bond Beam**  
9 7/8" x 7 5/8" x 15 5/8"

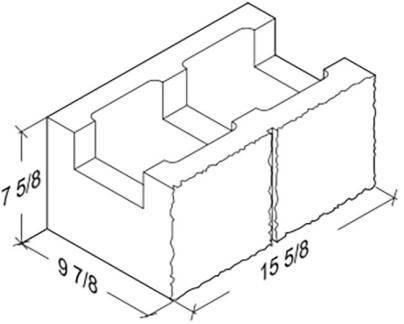

**10-8-16 1-Score Bond Beam**  
9 7/8" x 7 5/8" x 15 5/8"

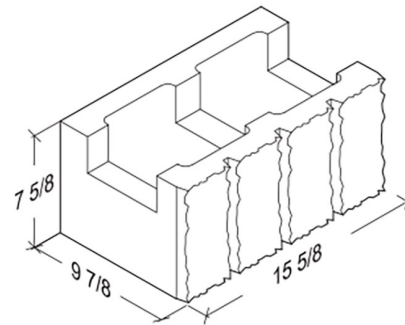

**10-8-16 3-Score Bond Beam**  
9 7/8" x 7 5/8" x 15 5/8"

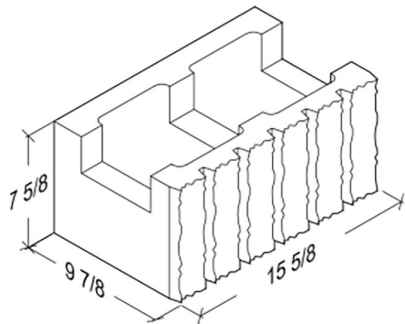

**10-8-16 5-Score Bond Beam**  
9 7/8" x 7 5/8" x 15 5/8"

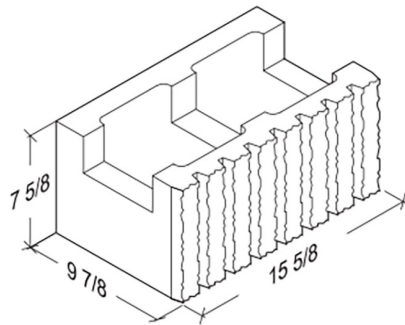

**10-8-16 7-Score Bond Beam**  
9 7/8" x 7 5/8" x 15 5/8"

# Ground Face

## 12-Inch Units

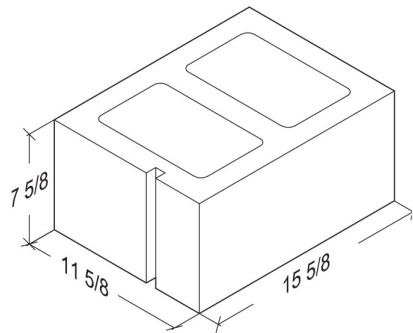

**12-8-16 Standard**  
11 5/8" x 7 5/8" x 15 5/8"

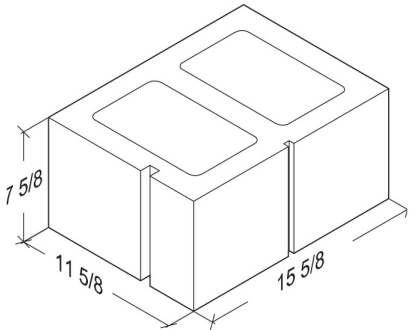

**12-8-16 1-Score**  
11 5/8" x 7 5/8" x 15 5/8"

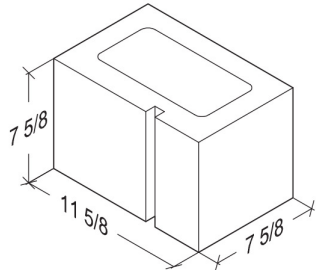

**12-8-8 Half**  
11 5/8" x 7 5/8" x 7 5/8"

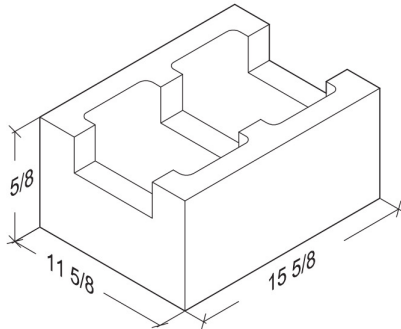

**12-8-16 Bond Beam**  
11 5/8" x 7 5/8" x 15 5/8"

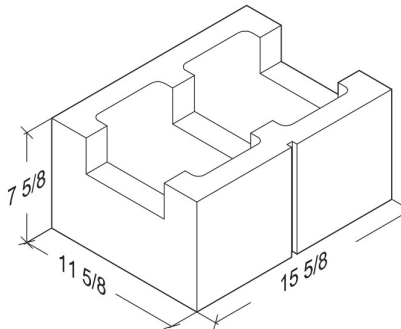

**12-8-16 1-Score Bond Beam**  
11 5/8" x 7 5/8" x 15 5/8"

# Split Face 12-Inch Units

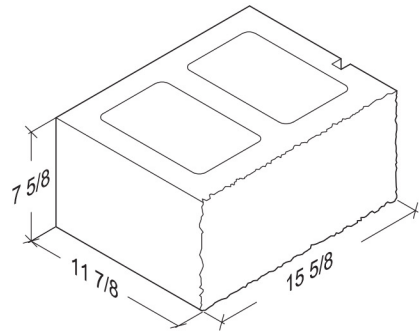

**12-8-16 Standard**

11 5/8" x 7 5/8" x 15 5/8"

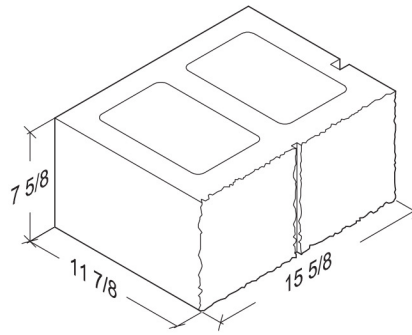

**12-8-16 1-Score**

11 5/8" x 7 5/8" x 15 5/8"

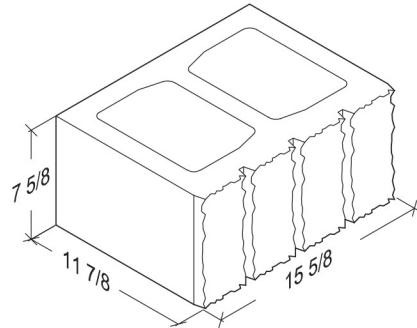

**12-8-16 3-Score**

11 5/8" x 7 5/8" x 15 5/8"

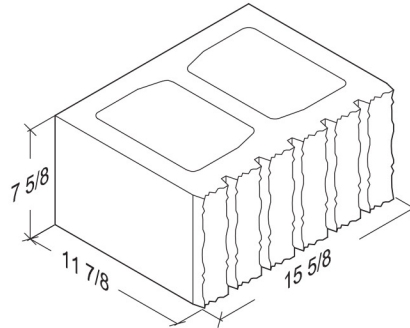

**12-8-16 5-Score**

11 5/8" x 7 5/8" x 15 5/8"

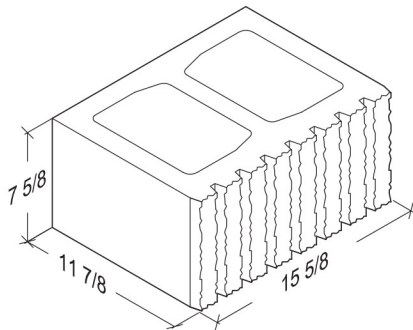

**12-8-16 7-Score**

11 5/8" x 7 5/8" x 15 5/8"

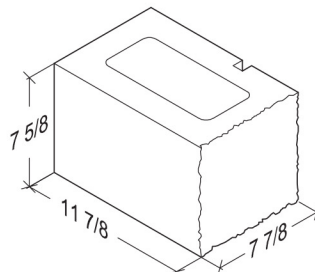

**12-8-8 Half**

11 5/8" x 7 5/8" x 7 5/8"

# Split Face 12-Inch Units

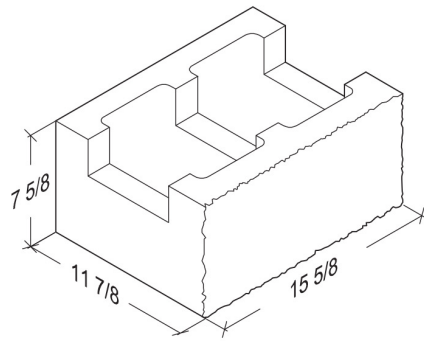

**12-8-16 Bond Beam**

11 5/8" x 7 5/8" x 15 5/8"

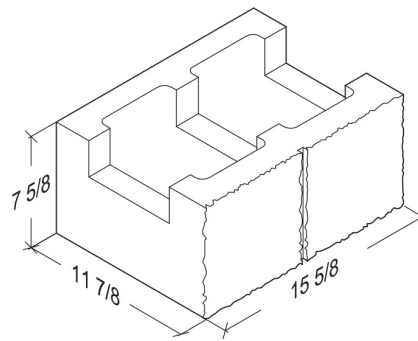

**12-8-16 1-Score Bond Beam**

11 5/8" x 7 5/8" x 15 5/8"

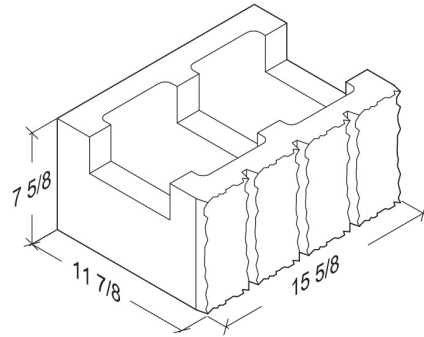

**12-8-16 3-Score Bond Beam**

11 5/8" x 7 5/8" x 15 5/8"

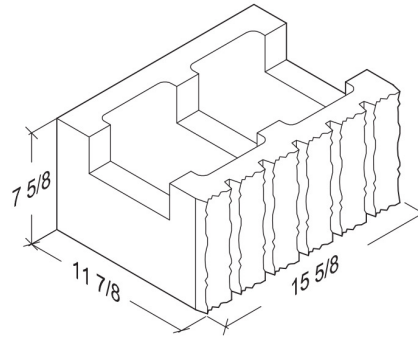

**12-8-16 5-Score Bond Beam**

11 5/8" x 7 5/8" x 15 5/8"

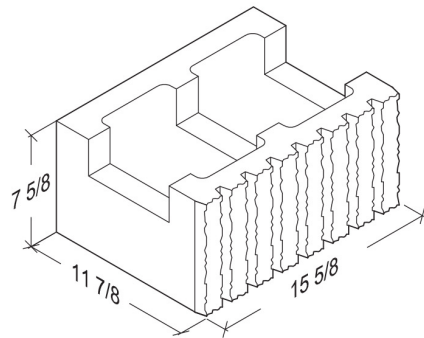

**12-8-16 7-Score Bond Beam**

11 5/8" x 7 5/8" x 15 5/8"

# Ground Face

## 8-Inch Lintels

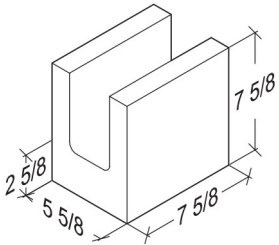

**6-8-8 Lintel**  
5 5/8" x 7 5/8" x 7 5/8"

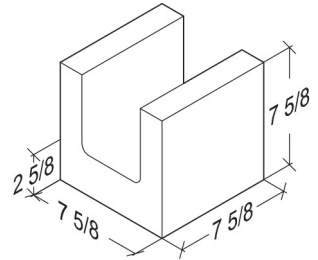

**8-8-8 Lintel**  
7 5/8" x 7 5/8" x 7 5/8"

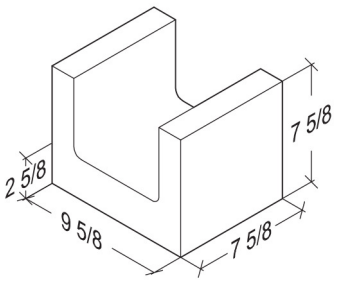

**10-8-8 Lintel**  
9 5/8" x 7 5/8" x 7 5/8"

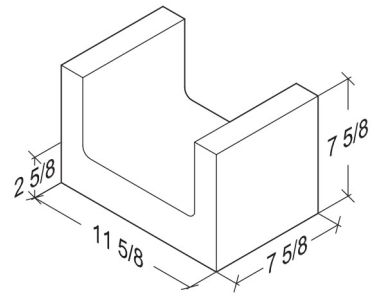

**12-8-8 Lintel**  
11 5/8" x 7 5/8" x 7 5/8"

# Ground Face 16-Inch Lintels

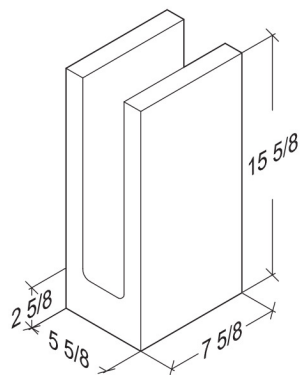

**6-8-16 Lintel**  
5 5/8" x 7 5/8" x 15 5/8"

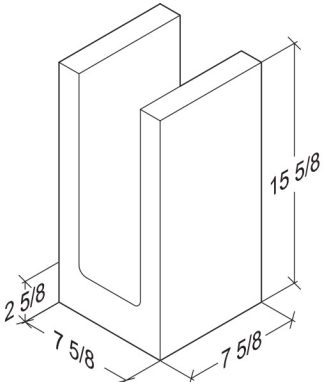

**8-8-16 Lintel**  
7 5/8" x 7 5/8" x 15 5/8"

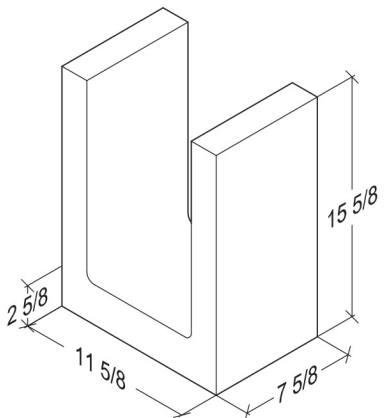

**12-8-16 Lintel**  
11 5/8" x 7 5/8" x 15 5/8"

# Ground Face L-Corners

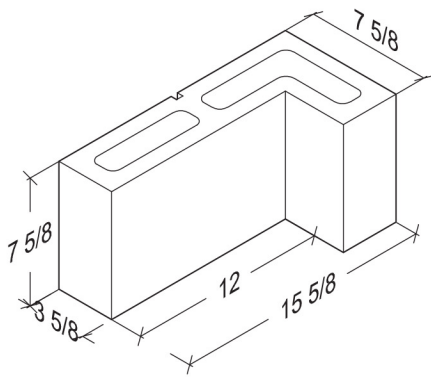

**4 Inch L-Corner**

7 5/8" x 7 5/8" x 15 5/8"

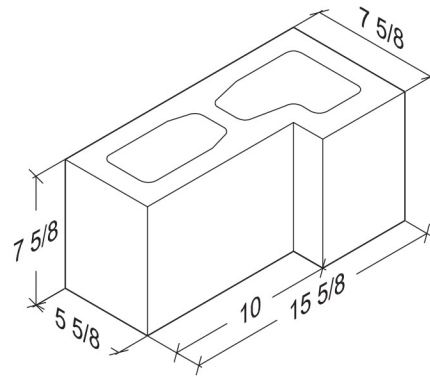

**6 Inch L-Corner**

7 5/8" x 7 5/8" x 15 5/8"



# Ground Face Sloped Caps

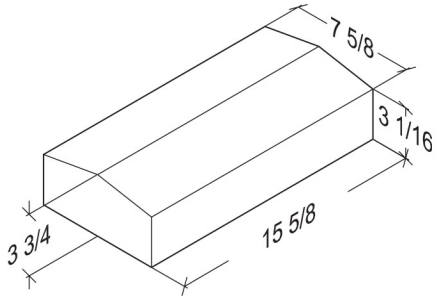

**8-4-16 Sloped Cap**  
7 5/8" x 3 3/4" x 15 5/8"

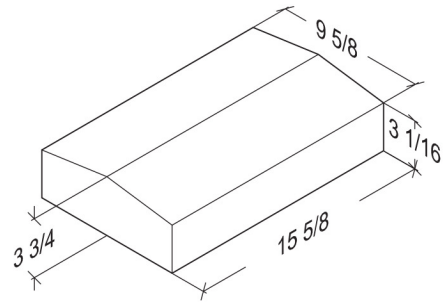

**10-4-16 Sloped Cap**  
9 5/8" x 3 3/4" x 15 5/8"

# Ground Face Sills

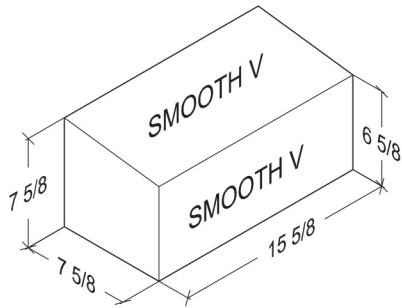

**8x8x16 Sloped Sill**

7 5/8" x 7 5/8" x 15 5/8"

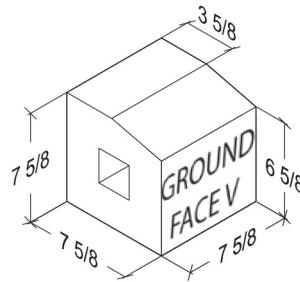

**8x8x8 Sloped Sill**

7 5/8" x 7 5/8" x 7 5/8"

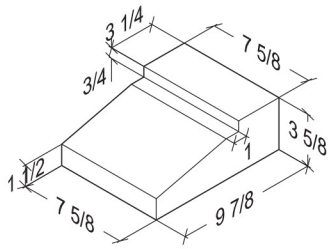

**10x4x8 Square Sill**

9 7/8" x 3 5/8" x 7 5/8"

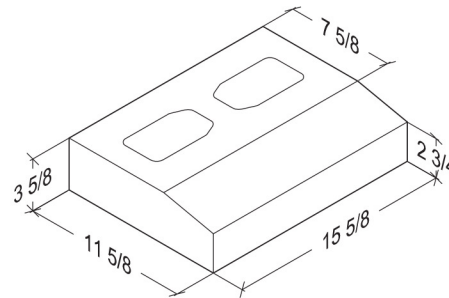

**12x4x16 Square Transition Sill**

11 5/8" x 3 5/8" x 15 5/8"

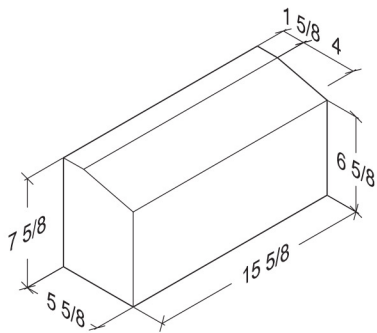

**6x8x16 - Chamfer A**

5 5/8" x 7 5/8" x 15 5/8"

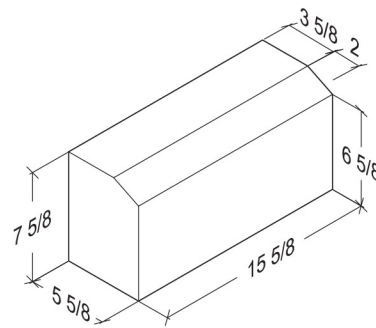

**6x8x16 Chamfer B**

5 5/8" x 7 5/8" x 15 5/8"